

# TOSHIBA

Leading Innovation >>>

## CAMERA CONTROL UNIT

## INSTRUCTION MANUAL

# IK-HD3D

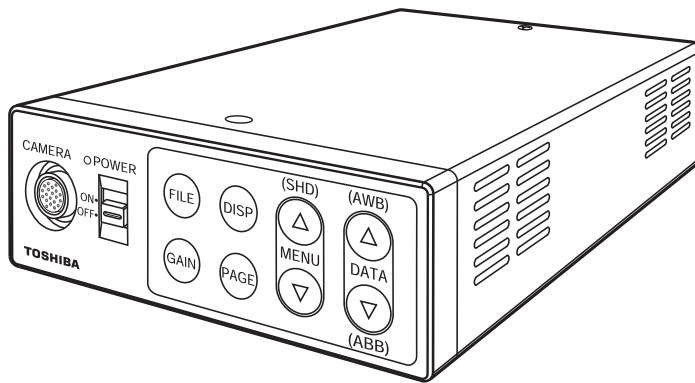

### For Customer Use

Enter below the Serial No. which is located on the bottom of the cabinet. Retain this information for future reference.

Model No.: IK-HD3D

Serial No.: \_\_\_\_\_

### U.S.A INFORMATION

This equipment has been tested and found to comply with the limits for a Class A digital device, pursuant to Part 15 of the FCC Rules. These limits are designed to provide reasonable protection against harmful interference when the equipment is operated in a commercial environment. This equipment generates, uses, and can radiate radio frequency energy and, if not installed and used in accordance with the instruction manual, may cause harmful interference to radio communications. Operation of this equipment in a residential area is likely to cause harmful interference in which case the user will be required to correct the interference at his own expense.

**USER-INSTALLER CAUTION:** Your authority to operate this FCC verified equipment could be voided if you make changes or modifications not expressly approved by the party responsible for compliance to Part 15 of the FCC Rules.

### Following information is only for EU-member states:

In residential areas this product may cause radio interference, therefore this product must not be used in residential areas.

The use of the symbol indicates that this product may not be treated as household waste. By ensuring this product is disposed of correctly, you will help prevent potential negative consequences for the environment and human health, which could otherwise be caused by inappropriate waste handling of this product. For more detailed information about the take-back and recycling of this product, please contact your supplier where you purchased the product or consult.



# SAFETY PRECAUTIONS

## Safety icons

This manual contains safety instructions that must be observed in order to avoid potential hazards that could result in personal injuries, damage to your equipment, or loss of data.

These safety cautions have been classified according to the seriousness of the risk, and the icons highlight these instructions as follows:

---

**▲ WARNING** Indicates a potentially hazardous situation which, if not avoided, could result in death or serious injury.

---

**▲ CAUTION** Indicates a potentially hazardous situation which, if not avoided, may result in minor or moderate injury.

---

**CAUTION** Indicates a potentially hazardous situation which, if not avoided, may result in property damage.

---

**▲ WARNING** **Stop operation immediately if any abnormality or defect occurs.**  
Use during an abnormal condition; such as emitting smoke, burning odors, damage from dropping, invasion of foreign objects, etc. may result in fire and/or electric shock. Immediately disconnect the power source and contact your dealer.

---

**▲ WARNING** **Avoid installing in a shower room or a bathroom.**  
This may result in fire and/or electric shock.

---

**▲ WARNING** **Do not operate in places where the product may get wet.**  
This may result in fire and/or electric shock.

---

**▲ WARNING** **Do not repair, disassemble and/or modify by yourself.**  
This may result in fire and/or electric shock. Be always sure to contact your dealer for internal repair, check and cleaning of the product.

---

**▲ WARNING** **Use the specified power supply.**  
Otherwise, fire or electrical shock may occur.

---

**▲ WARNING** **Do not place anything on top of the unit.**  
Foreign materials, such as metals or liquids into the product may result in fire and/or electrical shock.

---

**▲ WARNING** **Do not put the product on an unstable, slanted or vibrating surface.**  
The product dropping or falling may cause serious injury.

---

**▲ WARNING** **Do not touch the product or any connection cables during a thunderstorm.**  
This may result in electrical shock.

---

**CAUTION****Note the following instructions when installing.**

- Do not cover the product with any material.
- Do not place the product on any confined Inflammable material such as a carpet or blanket.
- Do not place the product in a narrow space, as this may cause heat to buildup inside the product.

Failure to follow the above cautions may result in fire.

**CAUTION****Do not place the product in direct sunshine and/or high temperature.**

Temperature build up inside the product may result in fire.

**CAUTION****Avoid placing in humid, smoky, vaporized or dusty places.**

This may result in fire and/or electric shock.

**CAUTION****Ask your dealer to perform a periodical check and internal cleaning (approx. once every five years).**

Dust inside the product may result in fire. For check and cleaning cost, please consult your dealer.

The following description is described the state that the suitable camera head is connected to this camera control unit.

**CAUTION****Do not point the lens directly at the sun and/or intensive light such as direct sunlight, etc.**

Focusing of the light may cause eye injury and/or fire.

## Disclaimer

We disclaim any responsibility and shall not be responsible for any damages or losses incurred by the user in any of the following cases:

1. Fire, earthquake or any other act of God; acts by third parties; misuse by the user, whether intentional or accidental; use under extreme operating conditions.
2. Malfunction or non-function resulting in indirect, additional or consequential damages, including but not limited to loss of expected income and suspension of business activities.
3. Incorrect use not in compliance with instructions in this instruction manual.
4. Malfunctions resulting from misconnection to other equipment.
5. Repairs or modifications made by the user or caused to be made by the user and carried out by an unauthorized third party.

Notwithstanding the foregoing, Toshiba America Information Systems, Inc.'s liabilities shall not, in any circumstances, exceed the purchase price of the product.

## Copyright and Right of Portrait

There may be a conflict with the Copyright Law and other laws when, the customer, uses, displays, distributes, or exhibits an image picked up by the camera without permission from the copyright holder. Please also note that transfer of an image or file covered by copyright is restricted to use within the scope permitted by the Copyright Law. You are solely responsible for complying with all applicable copyright laws.

## Protection of Personal Information

Images taken by the camera that reveal the likeness of an individual person may be considered personal information. To disclose, exhibit or transmit those images over the internet or otherwise, consent from such individual person may be required. You are solely responsible to obtain such consent.

## Limitation of Usage

The product is not designed for any “critical applications.” “Critical applications” means life support systems, exhaust or smoke extraction applications, medical applications, commercial aviation, mass transit applications, military applications, homeland security applications, nuclear facilities or systems or any other applications where product failure could lead to injury to persons or loss of life or catastrophic property damages. Accordingly, We disclaim any and all liability arising out of the use of the product in any critical applications.

## TABLE OF CONTENTS

<b>1. CAUTIONS ON USE AND INSTALLATION.....</b>	<b>6</b>
<b>2. COMPONENTS.....</b>	<b>6</b>
<b>3. ITEMS CONTROLLED BY THE SCREEN DISPLAY.....</b>	<b>7</b>
<b>4. NAMES AND FUNCTIONS.....</b>	<b>8</b>
<b>5. CONNECTION.....</b>	<b>9</b>
5.1 Standard Connection.....	9
5.2 Cautions on Connection.....	10
5.3 Connector Pin Assignments.....	10
<b>6. OPERATION.....</b>	<b>11</b>
6.1 Automatic Black Balance.....	11
6.2 White Balance.....	11
6.3 Scene File.....	12
6.4 Gain.....	13
6.5 Shading Correction.....	14
6.6 Switching of Video Signal Output.....	14
<b>7. MODE SETTING BY ON SCREEN DISPLAY.....</b>	<b>15</b>
7.1 Using the Menus.....	15
7.2 Menus.....	16
(1) SHUTTER (Electronic shutter).....	16
(1.1) Changing the setting in AUTO mode.....	17
(1.2) Changing the setting in MANUAL mode.....	19
(1.3) Changing the setting in SS (Synchro. Scan) mode.....	19
(2) GAIN (Video gain).....	20
(2.1) Changing maximum gain in AUTO (AGC: Automatic gain control) mode.....	20
(2.2) Changing gain in MANUAL mode.....	20
(3) WHT BAL (White balance).....	21
(3.1) Changing the setting in AWB (Automatic White Balance) mode.....	21
(3.2) Changing gain in MANUAL mode.....	22

( 4 )	PROCESS1 .....	23
	(4. 1) Changing gamma correction ON/OFF .....	23
	(4. 2) Changing gamma correction level .....	23
	(4. 3) Changing black gamma correction level .....	23
	(4. 4) Changing pedestal .....	24
	(4. 5) Change of white clip .....	24
( 5 )	PROCESS2 .....	25
	(5. 1) Changing detail (outline) gain .....	25
	(5. 2) Change of detail boost frequency .....	25
	(5. 3) Change of horizontal and vertical detail balance .....	25
	(5. 4) Changing DNR (Digital Noise Reduction) .....	25
( 6 )	PROCESS3 .....	26
	(6. 1) Changing matrix color correction ON/OFF .....	26
	(6. 2) Selection of matrix correction color .....	26
	(6. 3) Changing MATRIX setting .....	26
	(6. 4) Change of chroma gain .....	26
( 7 )	SYNC .....	27
	(7. 1) INT screen .....	27
	(7. 2) Changing EXT. setting .....	27
( 8 )	OPTION .....	28
	(8. 1) Changing shading correction mode .....	28
	(8. 2) Changing manual shading correction mode .....	28
	(8. 3) Changing detail signal output .....	28
	(8. 4) Change of vertical inversion setting .....	29
	(8. 5) Change of horizontal inversion setting .....	29
	(8. 6) Switching of inversion mode display .....	29
	(8. 7) Change of binning setting .....	29
	(8. 8) Change of monitor receiver types .....	29
	(8. 9) Change of I/P mode .....	29
	(8. 10) Changing RS-232C baud rate .....	29
( 9 )	Setting USER area .....	30
( 10 )	Returning to factory settings .....	31
	7. 3 External Sync .....	31
	7. 4 Synchro. Scan Operation .....	31
<b>8.</b>	<b>BEFORE MAKING SERVICE CALL .....</b>	<b>32</b>
<b>9.</b>	<b>SPECIFICATIONS .....</b>	<b>33</b>
<b>10.</b>	<b>EXTERNAL APPEARANCE DIAGRAM .....</b>	<b>34</b>

# 1. CAUTIONS ON USE AND INSTALLATION

- **Handling the unit.**

Do not drop, jolt, or vibrate, as this may result in damage to the unit and may cause problems. Treat the camera cables carefully to prevent cable problems, such as breaks in the cable and loose connections.

- **Install the camera in a location free from noise.**

If the camera or the cables are located near power utility lines or a TV, etc. undesirable noise may appear on the screen. In such a case, try to change the location of the camera or the cable wiring.

- **Operating ambient temperature and humidity.**

Do not use the camera in places where temperature and humidity exceed the specifications. Picture quality will deteriorate and internal parts may be damaged.

Be particularly careful when using in places exposed to direct sunlight. When shooting in hot environments, depending on the conditions of the object and the camera (for example when the gain is increased), noise in the form of vertical strips or white dots may occur. This is not a malfunction.

- **When not using the camera for extended periods of time.**

Switch the control unit off and disconnect the power supply.

- **Avoid using or storing the camera in the following places:**

Places filled with highly flammable and corrosive gas.

Places near gasoline, benzene, or paint thinner.

Places subject to strong vibration.

Places containing chemicals (such as pesticides), rubber or vinyl products for extended periods of time.

- **This product is for indoor use only.**

The following descriptions are for a camera head “IK-HD3H” “IK-HR3H” connected to this camera control unit.

- **Do not shoot intense light.**

If strong light is entered, vertical stripes or traverse bands may appear on the screen but this is not a failure.

- **Moire**

A moire pattern is an interference pattern generated when two repetitive line patterns overlap. This is not a malfunction. Eliminating the repetitive line patterns, or aligning the two patterns, will eliminate the moire.

- **Handling of the camera head and protection cap.**

Keep the camera head and protection cap away from children as they may pose a choking hazard. Because the protection cap protects the image sensing plane when the lens is removed from the camera head, do not discard the protection cap.

- **When cleaning the camera.**

Unplug the power source before cleaning. Clean with a soft dry cloth only. Do not use chemicals or chemically treated cloths. Chemicals may damage coatings and printed letters. When cleaning the lens, use lens cleaning paper.

- **Installation without a tripod.**

Before installing the camera head, make sure that the location can withstand the total weight of the camera head.

If this is not the case, reinforce the area to prevent the unit from dropping, which may result in damage to the unit or personal injury.

# 2. COMPONENTS

(1) Camera Control Unit .....	1
(2) Accessories	
(a) Instruction manual .....	1

### 3. ITEMS CONTROLLED BY THE SCREEN DISPLAY

Item		Available selections	Preset value (Factory setting)
Electronic shutter	MODE	AUTO, MANUAL, SS	MANUAL
	AUTO level	-100 – 0 – 100	0
	AUTO peak/average	00 : 10 – 05 : 05 – 10 : 00	05 : 05
	AUTO response speed	1 – 10 – 20	10
	AUTO area	PRESET A, PRESET B, PRESET C, PRESET D, PRESET E, USER (USER area is possible to set in 64 zones)	PRESET A
	Maximum AUTO shutter speed	1/200s, 1/250s, 1/300s, 1/350s, 1/400s, 1/450s, 1/500s, 1/550s, 1/600s, 1/700s, 1/800s, 1/900s, 1/1000s, 1/1200s, 1/1500s, 1/2000s, 1/4000s, OFF	OFF
	MANUAL shutter speed	OFF, 1/100s, 1/125s, 1/250s, 1/500s, 1/1000s, 1/2000s, 1/3000s, 1/4000s, 1/5000s, 1/10000s	OFF
	Syncro. scan	1/1125H – 1122/1125H, OFF	OFF
Gain	MODE	AUTO, MANUAL, OFF	OFF
	AUTO maximum gain	0dB to 20dB	20dB
	MANUAL gain	-3dB to 20dB	0dB
White balance	MODE	AWB, MANUAL	AWB
	Color temperature	3200K, 5600K	3200K
	AWB R PAINT	-10 – 0 – 10	0
	AWB B PAINT	-10 – 0 – 10	0
	AWB area	PRESET A, PRESET B, PRESET C, PRESET D, PRESET E, USER (USER area is possible to set in 64 zones)	PRESET A
	MANUAL R GAIN	-100 – 0 – 100	0
	MANUAL B GAIN	-100 – 0 – 100	0
Gamma correction		ON, OFF	ON
Gamma correction level		-10 – 0 – 10	0
Black gamma correction level		LOW, NORMAL, HIGH	NORMAL
Master pedestal		-200 – 0 – 200	0
Red pedestal		-100 – 0 – 100	0
Blue pedestal		-100 – 0 – 100	0
White clip		100% – 109%	109%
Detail gain		0 – 10 – 31	10
Detail boost frequency		1 – 10 – 16	10
HV balance		8/16 – 16/16 – 24/16 (ratio of V/H)	16/16
Digital noise reduction (DNR)		ON, OFF	OFF
Matrix	Correction ON/OFF	ON, OFF	ON
	Selection of correction color	R, R-Ye, Ye, Ye-G, G, G-Cy, Cy, Cy-B, B, B-Mg, Mg, Mg-R	R
	Phase	-15 – 0 – 15	0
	Gain	-15 – 0 – 15	0
Chroma gain		-31 – 0 – 31	0
Ext. Sync	H phase adjustment	-650 – 0 – 650	0
Shading correction mode		SET, MANUAL, OFF	OFF
Manual shading correction		-128 – 0 – 127	0
Detail signal output		ON, OFF	OFF
Vertical inversion		ON, OFF	OFF
Horizontal inversion		ON, OFF	OFF
Inversion mode display switch		ON, OFF	OFF
Binning		ON, OFF	OFF
Monitor		PC, TV	PC
I/P mode		1080p, 1080i	1080p
RS-232C baud rate		9600bps, 19200bps	9600bps

## 4. NAMES AND FUNCTIONS

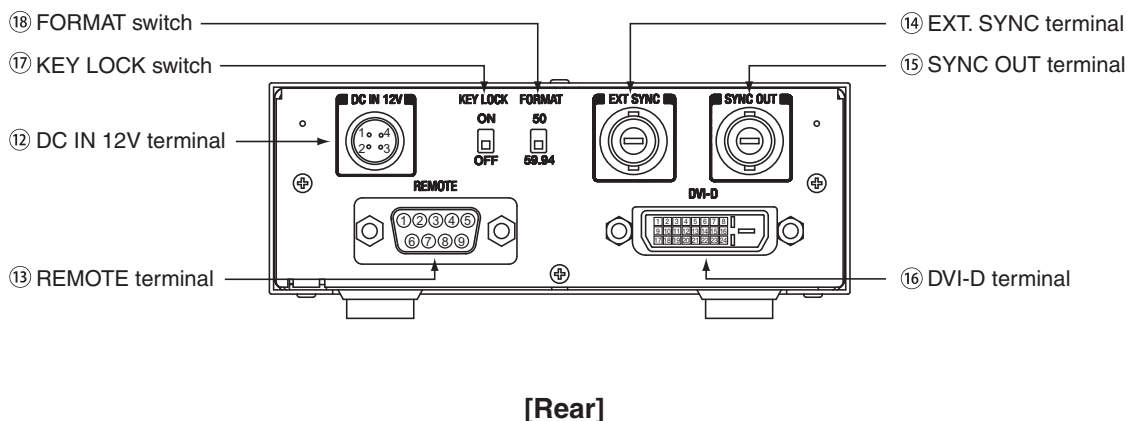
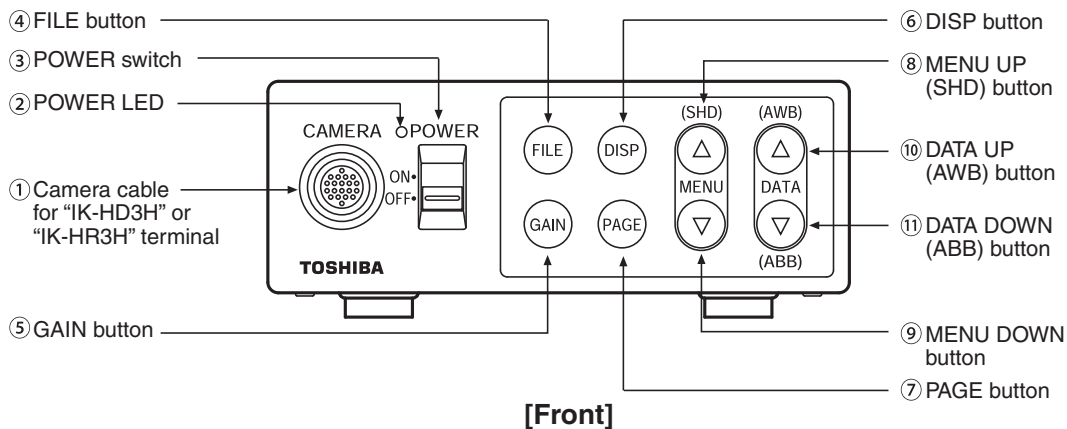

- |  |  |
|--|--|
| ① Camera cable for "IK-HD3H" or "IK-HR3H" terminal | Where the camera cable for "IK-HD3H" or "IK-HR3H" is connected.  |
| ② POWER LED  | Illuminates to indicate the unit is powered on.  |
| ③ POWER switch                                     | Turns power on or off.   |
| ④ FILE button                                      | To switch the scene files.   |
| ⑤ GAIN button                                      | To change the gain mode.   |
| ⑥ DISP button                                      | Changes the display mode.  |
| ⑦ PAGE button                                      | To switch and select menus.  |
| ⑧ MENU UP (SHD) button                             | To select the function to be confirmed or changed on the menu.<br>(Also used when performing auto shading correction.) |
| ⑨ MENU DOWN button                                 | To select the function to be confirmed or changed on the menu.   |
| ⑩ DATA UP (AWB) button                             | To change the value of the function selected by the MENU (UP/DOWN) button.<br>(Also used when performing an AWB.)      |
| ⑪ DATA DOWN (ABB) button                           | To change the value of the function selected by the MENU (UP/DOWN) button.<br>(Also used when performing an ABB.)      |



- |                      |   |
|----------------------|---|
| ⑫ DC IN 12V terminal | Accepts a DC power input (12V).   |
| ⑬ REMOTE terminal    | To connect to a RS-232C device for remote control function.                               |
| ⑭ EXT. SYNC terminal | Used when the camera output signal is synchronized to an external signal. (BNC connector) |
| ⑮ SYNC OUT terminal  | Output terminal for synchronization signal. (BNC connector)                               |
| ⑯ DVI-D terminal     | DVI-D output terminal.  |
| ⑰ KEY LOCK switch    | Enables/disables buttons ④ to ⑩.  |
| ⑱ FORMAT switch      | Switches between 59.94Hz and 50Hz.  |

## 5. CONNECTION

### 5.1 Standard Connection

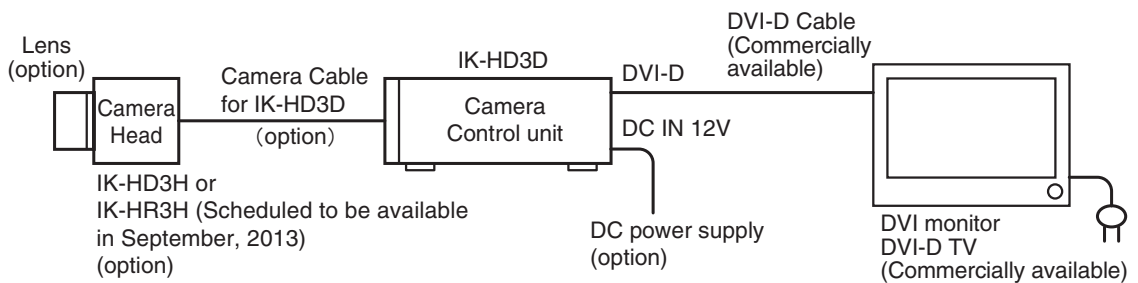

## 5.2 Cautions on Connection

- When connecting the camera cables, be sure to turn off the camera control unit and any other equipment connected to it.
- For DC power supply connecting to DC IN 12V terminal, use class II DC power supply approved according to EN60950-1 in Europe. or use UL listed and/or CSA approved ungrounded type AC adaptor with the specifications described below in U.S.A. or Canada.

Power supply voltage : 12V DC  $\pm$ 10%  
 Current rating : More than 1.5A  
 Ripple voltage : Less than 50 mV (p-p)  
 Connector : HR10A-7P-4S by HIROSE electronics Co. Ltd  
 Pins 1, 2 : 12V  
 Pins 3, 4 : GND

- If the securing screw on the connector of the camera cable loosens, noise may appear on the screen. Be sure to tighten the connector completely.
- Only use the specific optional camera heads with this camera controller.  
 The use of any other camera heads may cause damage to the control unit and camera head.
- The video signal output of this camera control unit has no function for automatically selecting output according to the resolution of DVI monitor TV. Therefore, be sure to switch the output mode of this camera control unit according to the monitor's resolution as no image will be displayed on the monitor if the camera output mode and the monitor input mode do not match. For switching, refer to the item 6.6 "Switching of Video Signal Output".
- DVI standard  
 The DVI (digital visual interface) is the connection interface standard for flat-panel display (FPD) such as LCD displays. There are three types of DVI connectors, namely DVI-I (for both digital/analog), DVI-D (exclusively for digital) and DVI-A (exclusively for analog). Use a commercially available DVI-D cable for this camera control unit.

## 5.3 Connector Pin Assignments

On the rear panel of the camera control unit, DC IN 12V terminal used for basic connection and REMOTE, EXT SYNC, SYNC OUT and DVI-D terminal are provided. Connect cables depending on your necessity.

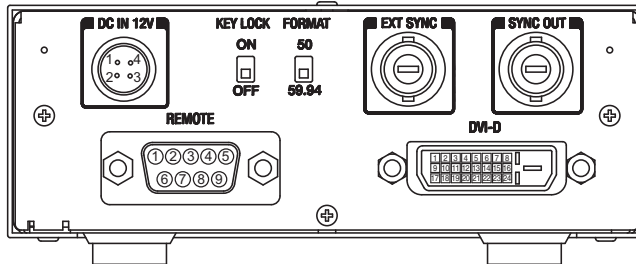

DC IN 12V terminal

1	+12V
2	+12V
3	GND
4	GND

REMOTE terminal

1	NC
2	TXD
3	RXD
4	NC
5	GND
6	NC
7	NC
8	NC
9	NC

DVI-D terminal

1	Data2-	13	NC
2	Data2+	14	+5V
3	Data2 Shield (GND)	15	GND
4	NC	16	Hot Plug Detect
5	NC	17	Data0-
6	NC	18	Data0+
7	NC	19	Data0 Shield (GND)
8	NC	20	NC
9	Data1-	21	NC
10	Data1+	22	Clock Shield (GND)
11	Data1 Shield (GND)	23	Clock+
12	NC	24	Clock-

## 6. OPERATION

A camera head needs to be connected to this camera control unit from this section on.

- ① Refer to the item “5. CONNECTION”, connect the equipment correctly.
- ② Turn on the connected equipment and the camera.
- ③ When using the camera for the first time and when replacing the camera head, be sure to perform the ABB adjustment, refer to the item “6.1 Automatic Black Balance”.
- ④ Aim the lens at the object, adjust the lens iris adjustment, focus adjustment, etc.
- ⑤ Refer to the item “6.2 White Balance”, make the adjustment.
- ⑥ Refer to the items “6.3 Scene File, 6.4 Gain, 7. MODE SETTING BY THE ON SCREEN DISPLAY”, select the necessary items.

### 6.1 Automatic Black Balance

Black balance adjustment is necessary to get the correct black picture level.

- Close the lens iris.
- If the color bar pattern is displayed on the screen or if the index menu/menu is displayed, press the [DISP] button to disable the color bar pattern or the character display.
- Hold the [DATA DOWN] button for approx. 1 second.
- When the black balance adjustment operation starts, the character ABB blinks on the screen.
- When the black balance adjustment operation finishes, the character ABB stops blinking and the result appears for approx. 1 second.

Display	Meaning
<b>ABB OK</b>	Automatic black balance adjustment finished correctly.
<b>ABB NG</b> <b>CLOSE LENS</b>	Automatic black balance adjustment cannot be performed because the lens iris is open. Close the lens iris.
<b>ABB NG</b>	Automatic black balance adjustment cannot be performed. Operate the automatic black balance again.

### 6.2 White Balance

For white balance adjustment of this unit, AWB (Automatic White Balance) and MANUAL (Manual white balance) adjustments are provided. Refer to the items “7.2 (3) WHT BAL (White Balance), 7. MODE SETTING BY THE ON SCREEN DISPLAY”, select the desired mode.

	<b>AWB</b> <b>(Automatic White Balance)</b>	<b>MANUAL</b> <b>(Manual White Balance)</b>
<b>Outline</b>	Adjust white balance by displaying a white object inside the area set by AWB menu and holding the [DATA UP] button for approx. 1 second.	Adjust the white balance manually using the WHT BAL menu while shooting a white object.
<b>Features</b>	Automatically adjusts red and blue balance based on green for the object in the designated area .	White balance can be set manually.
<b>Note</b>	When no white object exists in the designated area or lighting is too blight or too dark, AWB NG is displayed and automatic white balance adjustment can not be performed.	Adjustment is performed by confirming with a monitor etc.

① AWB (Automatic white balance)

- Set the MODE to AWB on the WHT BAL menu.  
Perform the C.TEMP (color temperature conversion) setting, if necessary.  
(Refer to the item “7.2 (3) WHT BAL (White Balance)”.)
- 3200K : Appropriate for indoor shooting.
- 5600K : Appropriate for outdoor shooting.
- If the color bar pattern is displayed on the screen or if the index menu/menu is displayed, press the [DISP] button to disable the color bar pattern or the character display on the menu.
- Shoot a known white object entirely in the area set by the AWB menu (refer to the item “7.2 (3) (3.1) (d) Confirming the contents of the zone area selected by AWB” ) and push [DATA UP] button for approx. 1 second.
- The character AWB blinks on the screen when the AWB starts.
- The character AWB stops blinking when the AWB finishes, and the result is displayed for approx. 1 second.

Display	Meaning
<b>AWB OK</b>	Automatic white balance adjustment finished correctly.
<b>AWB NG LEVEL LOW</b>	Automatic white balance adjustment cannot be performed because the video level is too low. Adjust the video level by increasing the illumination or opening the lens iris.
<b>AWB NG LEVEL HIGH</b>	Automatic white balance adjustment cannot be performed because the video level is too high. Adjust the video level by decreasing the illumination or closing the lens iris.
<b>AWB NG C.TEMP LOW</b>	Automatic white balance adjustment cannot be performed because the color temperature is too low. If the C.TEMP is set to 5600K, set to 3200K. If the message appears with the C.TEMP set to 3200K, change the illumination or use a color temperature conversion filter.
<b>AWB NG C.TEMP HIGH</b>	Automatic white balance adjustment cannot be performed because the color temperature is too high. If the C.TEMP is set to 3200K, set to 5600K. If the message appears with the C.TEMP set to 5600K, change the illumination or use the color temperature conversion filter.
<b>AWB NG</b>	Automatic white balance adjustment cannot be performed for other reasons. Such as no white area is included in an object, etc.

② MANUAL (Manual white balance)

- Set the MODE to MANUAL on the WHT BAL menu.  
(Refer to the item “7.2 (3) WHT BAL (White Balance)”.)
- Shoot a known white object, set the white balance by adjusting the levels of R GAIN and B GAIN on the menu, confirming with a monitor or a vector scope.  
(Refer to the item “7.2 (3) (3.2) Changing gain in MANUAL mode”.)

### 6.3 Scene File

Five scene files (A, B, C, D, E) are available as user memories for this unit. These are chosen depending on shooting conditions. By using the [FILE] button, the camera operation is changed immediately from the currently selected Scene File to the next. (Refer to the item “7. MODE SETTING BY THE ON SCREEN DISPLAY”.)

- While any menu is displayed, pressing the [FILE] button will display the menu settings for the next Scene File:



- If the color bar pattern is displayed on the screen, press the [DISP] button to switch to the video signal screen.
- When the [FILE] button is pressed while the video signal screen is displayed, the current scene file selection at that time is displayed for approx. 3 seconds in the upper right corner of the screen. If the [FILE] button is pressed again while the position is displayed, the scene file cycles as described above.

**Note:**

The scene file does not include the data set in “I/P MODE” “BAUD RATE” within the “OPTION” menu.  
Refer to the item “7.2 (8) Menus” for the contents that can be set in OPTION.

## 6.4 Gain

When the image is dark even if the lens iris is open, change the gain (video gain) to get the desired video level. For gain adjustment of the unit, AUTO (Automatic gain control), MANUAL (Manual gain control), OFF (0 dB) modes are provided. Select the mode on the GAIN menu. (Refer to the item “7.2 (2) GAIN (Video gain)”.)

① AUTO (Automatic gain control)

When the output is low, gain is automatically adjusted to a suitable video level.

The maximum value of gain is 20dB, and can be set from 0 to 18dB in 1dB steps. (Refer to the item “7.2 (2) (2.1) Changing the maximum gain in AUTO (Automatic gain control) mode”.)

Video level (LEVEL), peak average value ratio (PEAK/AVE), measurement light area (AREA), and response speed (SPEED) are linked to the setting on the automatic shutter. (Refer to the item “7.2 (1) (1.1) Changing the setting in AUTO mode”.)

② MANUAL (Manual gain)

Gain adjustment is performed on the GAIN menu. The adjustment range is from -3 to 20dB in 1dB steps. (Refer to the item “7.2 (2) (2.2) Changing gain in MANUAL mode”.)

③ OFF

Gain is fixed at 0 dB.

### Gain button

① If the [GAIN] button is pressed, the current gain setting is displayed for approx. 3 seconds.

GAIN menu : OFF → GAIN OFF

SS : AUTO → GAIN AUTO

AUTO : MANUAL \*\* dB → GAIN dB

※ “\*\*” shows the setting gain in MANUAL mode.

② If the [GAIN] button is pressed again while the current setting mode is displayed, the gain mode can be changed. GAIN of MAX GAIN in AUTO mode and MANUAL mode can not be changed.



### Note:

White, red, green, or blue dots may occur when the gain is increased. This is not a malfunction, just certain characteristics of the CMOS sensor becoming more visible.

## 6.5 Shading Correction

Due to the lens used or the environmental condition, color shading may occur at the upper and lower edge of the screen. If this happens, the shading correction function can be used to decrease the amount of color shading. For shading correction of the unit, SET (Automatic shading correction), MANUAL (Manual shading correction), and OFF (no shading correction) modes are provided. Select the mode on the OPTION menu. (Refer to the item “7.2 (8) (8.1) Changing shading correction mode”.)

### ① SET (Auto shading)

- If the color bar pattern is displayed on the screen or if the index menu/menu is displayed, press the [DISP] button to remove them from the screen.
- Push the [MENU UP] button for approx. 1 second.
- When the automatic shading correction operation starts, the character SHD blinks on the screen.
- When the automatic shading correction operation terminates, the character SHD ends blinking and the result is displayed for approx. 1 second.

Display	Meaning
SHD OK	Automatic shading correction operation finished correctly.
SHD OK LIMIT	Automatic shading correction operation finished, however, the correction necessary exceeds the camera's range so the maximum possible value is applied.
SHD NG LEVEL LOW	Automatic shading correction cannot be performed because the video level is too low. Adjust the video level by increasing the illumination or opening the lens iris.
SHD NG LEVEL HIGH	Automatic shading correction cannot be performed because the video level is too high. Adjust the video level by decreasing the illumination or closing the lens iris.

### ② MANUAL (Manual Shading)

Perform the correction amount setting on the OPTION menu, confirming with a monitor or a vector scope. (Refer to the “7.2 (8) (8.2) Changing manual shading correction mode”.)

### ③ OFF

The status is no shading correction.

**\* Shading correction is only effective when the lens iris and zoom ratio is fixed. Use the unit with SHADING OFF for variable lens conditions.**

#### Note:

Implement shading correction after white balance adjustment by shooting a white object that fills the screen in the proper video level. IK-HD3H (3CMOS camera head) needs adjustment because it uses prism to split light and white shading may appear depending on the entrance angle against the lens exit pupil and prism. IK-HR3H (Scheduled to be available in September, 2013) will not have this function because it does not need adjustment described above.

## 6.6 Switching of Video Signal Output

### ① Switching of I/P modes

The image output can be changed between “1080p” and “1080i” by turning on the power supply while pushing the [DATA UP] or [DATA DOWN] button.

- Turn on the power supply while pushing the [DATA UP] button. The image output becomes “1080p”, and “1080p” is displayed on the monitor screen.
- Turn on the power supply while pushing the [DATA DOWN] button. The image output becomes “1080i”, and “1080i” is displayed on the monitor screen.

### ② Switching of vertical frequency

Turn the FORMAT switch to the “59.94” position for switching to “59.94Hz”.

Turn the FORMAT switch to the “50” position for switching to “50Hz”.

(Refer to the item “4. NAMES AND FUNCTIONS, ⑱ FORMAT switch”.)

# 7. MODE SETTING BY ON SCREEN DISPLAY

Various settings can be controlled on the unit by using the on screen menu displayed on the monitor. The contents once set are memorized in the scene files (A, B, C, D, E) selected, so if the power turns off, it is unnecessary to set again when using the unit next time. When the setting is performed, select the menu of the item to be set.

**Note:**

Displayed texts while pressing the screen menu, auto white balance (AWB) or other menus are output to the taken videos. These texts on the videos are not removable after the videos are recorded. Therefore, be careful when you operate the screen menu, AWB and other menus.

## 7.1 Using the Menus

When the power turns on, the normal screen showing only the video signal appears. Change the output to each screen (video signal output, color bar screen, Index menu, menus, and area menu) by using the [DISP], [PAGE], [MENU UP], and [MENU DOWN] buttons.

\* A menu is selected when pushing the [PAGE] button after moving the “→” the screen by the [MENU UP], [MENU DOWN] button while the Index menu is displayed.

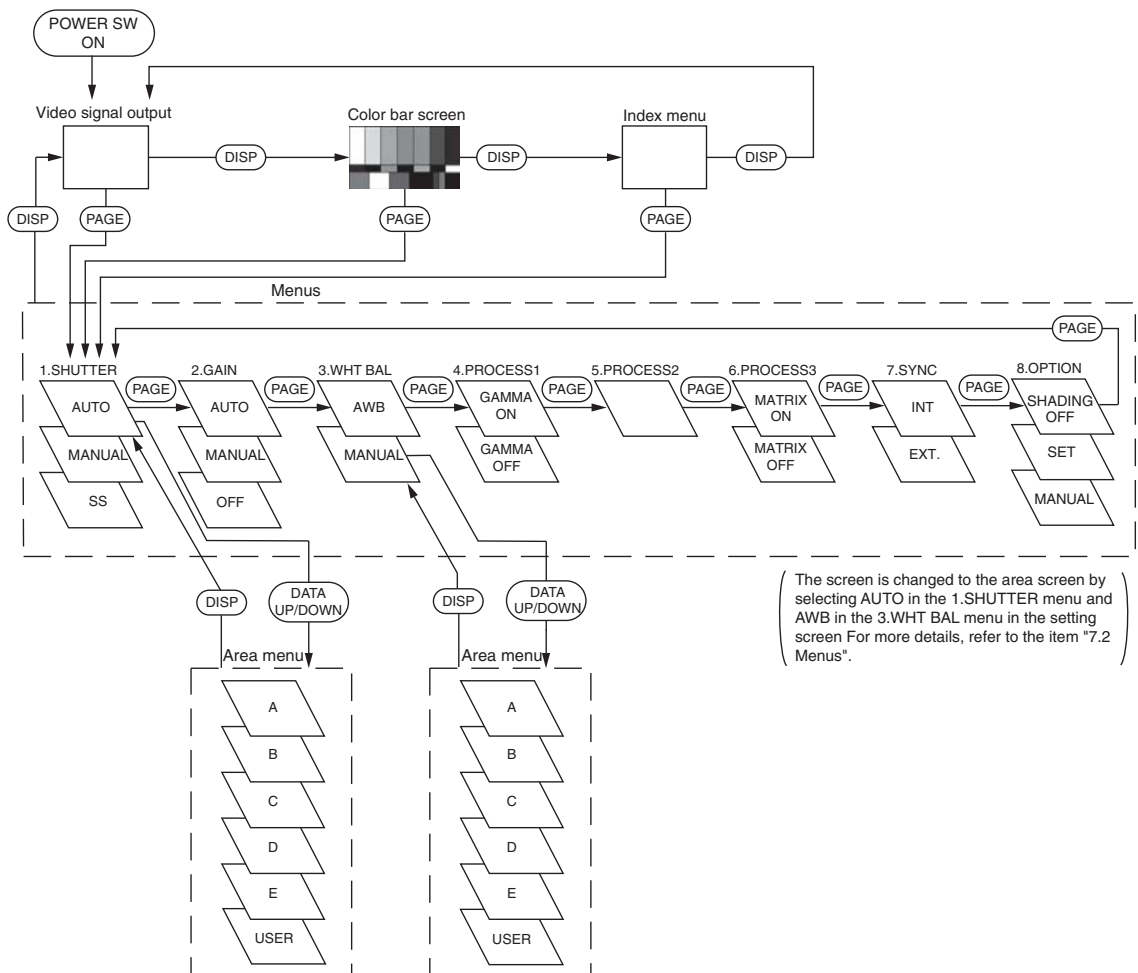

## 7.2 Menu

- Select the menu to change the setting by referring to the item “7.1 Using the Menus”.
- When the [MENU UP], [MENU DOWN] buttons are pushed, the “→” on the screen moves up and down. Move the “→” to the item whose setting you wish to change.

### ( 1 ) SHUTTER (Electronic shutter)

The electronic shutter has three modes; AUTO, MANUAL, SS(Synchro. Scan).

Press the “Page” button to enter the Shutter Page. Use the “Data Up/Down” buttons to select the Shutter Mode.



**AUTO** : The exposure time is controlled automatically to obtain the video level set.

**MANUAL** : It is possible to select the exposure time from eleven speed settings; OFF (at 1/60s: 59.94Hz setting and 1/50s: 50Hz setting), 1/100s, 1/125s, 1/250s, 1/500s, 1/1000s, 1/2000s, 1/3000s, 1/4000s, 1/5000s, 1/10000s.

**SS** : Shutter speed can be set by the horizontal scanning time (1H) unit.

#### Notes:

- If the shutter speed is increased, the sensitivity is decreased according to the speed. Flicker may be large under discharge lamp lighting such as fluorescent tubes.
- If a fast-moving object is shot, its image may be distorted or blurred. Horizontal light-and-dark stripes may appear on the screen under discharge lamp lighting such as fluorescent tubes. A light and dark difference may appear on the screen according to the light emitting timing of flash or strobe. These phenomena are caused due to rolling shutter system, not failures.
- When the shutter speed is set to high, the hue may change according to the shooting conditions and the object.



### (1. 1) Changing the setting in AUTO mode

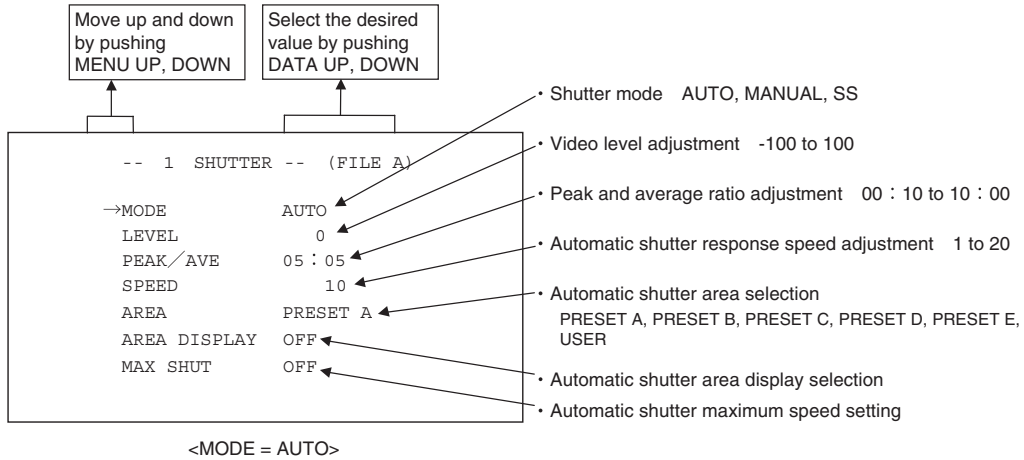

#### (a) Changing the video level in the automatic shutter mode

- Move the “→” to LEVEL by pushing the [MENU UP], [MENU DOWN] buttons.
- Select the video level by pushing the [DATA UP], [DATA DOWN] buttons.

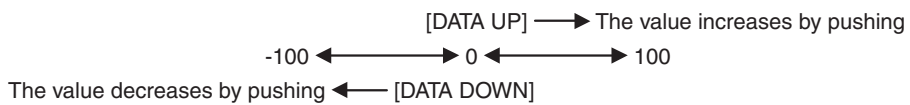

#### (b) Changing the automatic shutter detection (ratio between peak and average value)

- Move the “→” to PEAK/AVE by pushing the [MENU UP], [MENU DOWN] buttons.
- Select the ratio between peak and average value by pushing the [DATA UP], [DATA DOWN] buttons.

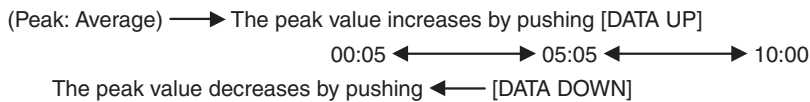

#### (c) Changing the automatic shutter response speed

- Move the “→” to SPEED by pushing the [MENU UP], [MENU DOWN] buttons.
- Select the response speed by pushing the [DATA UP], [DATA DOWN] buttons.

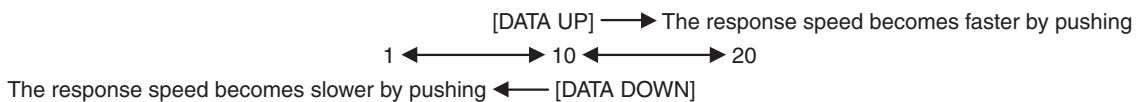

**(d) Changing the automatic shutter response speed**

- ① Move the “→” to AREA by pushing the [MENU UP], [MENU DOWN] buttons.
- ② Select the measurement light area by pushing the [DATA UP], [DATA DOWN] buttons.

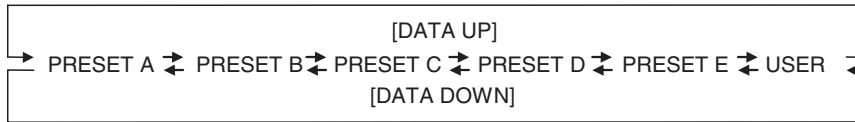

The available picture area is shown by the shading correction on the screen that is parted in 64.

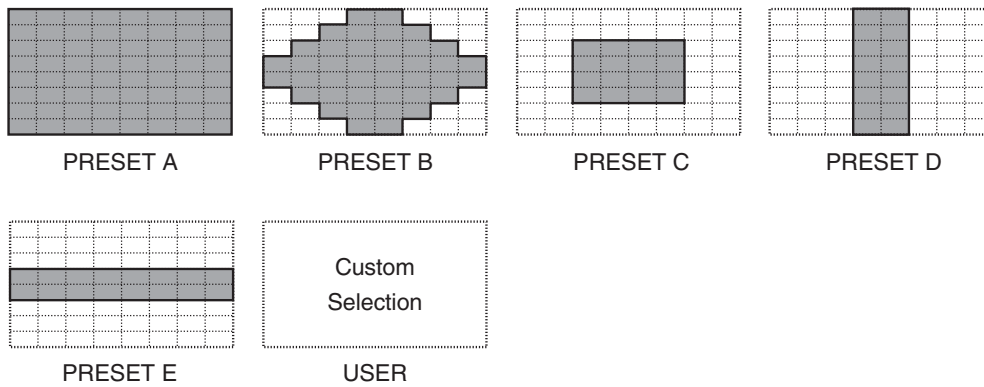

**(e) Confirming the contents of the measurement light area selected by the automatic shutter**

- ① Move the “→” to AREA DISPLAY by pushing the [MENU UP], [MENU DOWN] buttons.
- ② Area screen appears by pushing the [DATA UP], [DATA DOWN] buttons.  
When AREA is set to USER, the setting can be changed on the area menu. When changing the area, refer to the item “7.2 (8) Setting USER area”.
- ③ Push the [DISP] button to return to the menu.

**(f) Setting of maximum auto shutter speed**

- ① Move the “→” to MAX SHUT by pushing the [MENU UP], [MENU DOWN] buttons.
- ② Select the shutter speed by pushing the [DATA UP], [DATA DOWN] buttons.

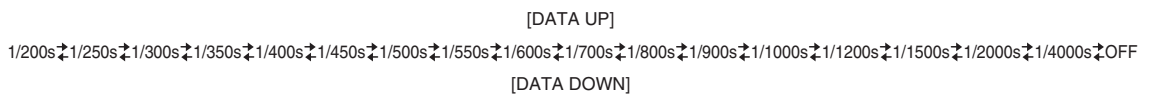

## (1.2) Changing the setting in MANUAL mode

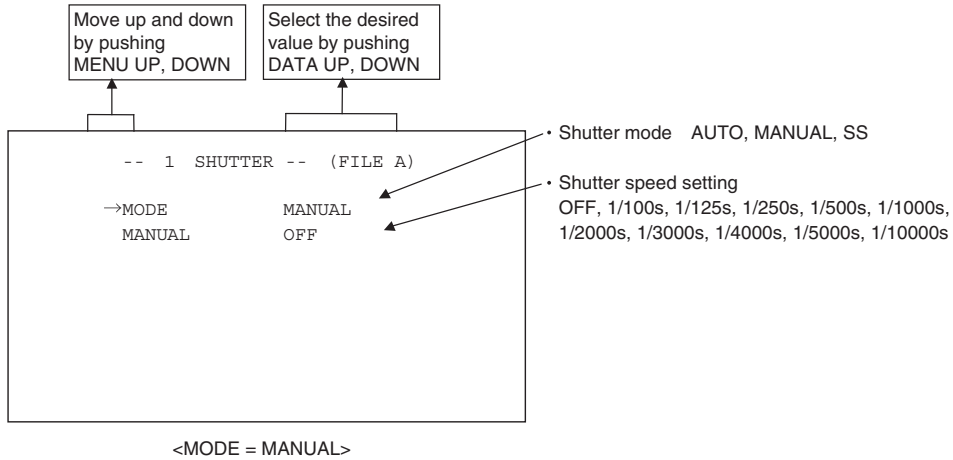

### (a) Changing the shutter speed

- ① Move the "→" to MANUAL by pushing the [MENU UP], [MENU DOWN] buttons.
- ② Select the shutter speed by pushing the [DATA UP], [DATA DOWN] buttons.

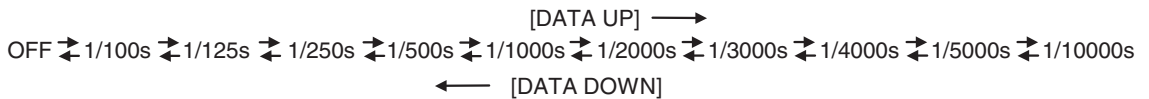

## (1.3) Changing the setting in SS (Synchro. Scan) mode

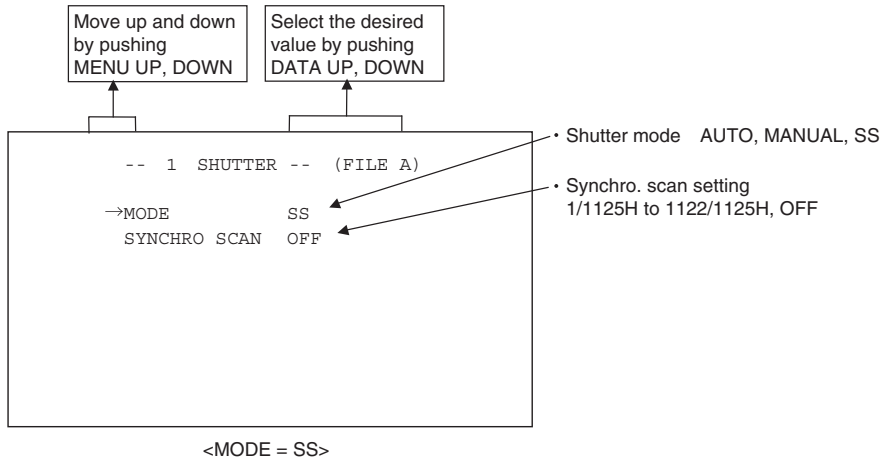

### (a) Changing the Synchro. Scan setting

- ① Move the "→" to SYNCHRO SCAN by pushing the [MENU UP], [MENU DOWN] buttons.
- ② Select the Synchro. Scan by pushing the [DATA UP], [DATA DOWN] buttons.

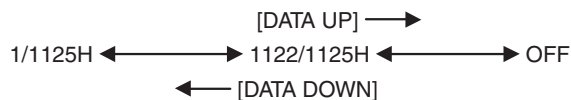

## ( 2 ) GAIN (Video gain)

GAIN has three modes; AUTO, MANUAL, OFF.

Move the “→” to MODE, push the [DATA UP], [DATA DOWN], and select one of the three modes: AUTO, MANUAL, OFF. In the OFF mode, gain is fixed to 0dB.

### (2. 1) Changing maximum gain in AUTO (AGC: Automatic gain control) mode

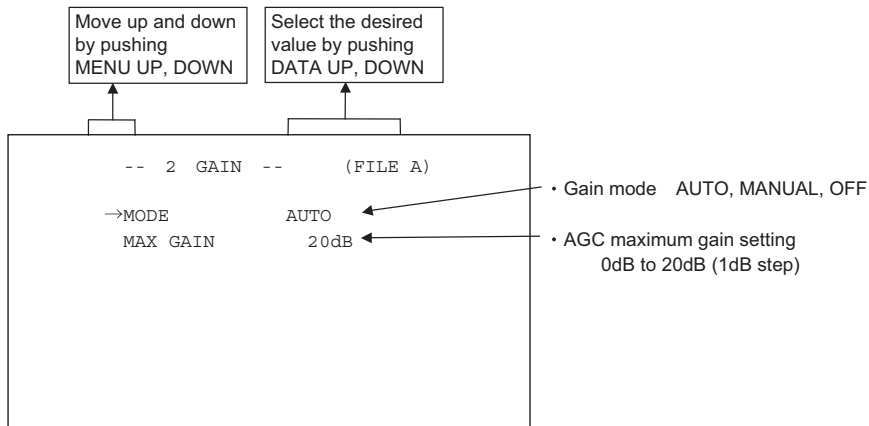

- ① Move the “→” to MAX GAIN by pushing the [MENU UP], [MENU DOWN] buttons.
- ② Select the desired value of AGC maximum gain by pushing the [DATA UP], [DATA DOWN] buttons.

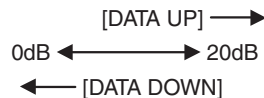

### (2. 2) Changing gain in MANUAL mode

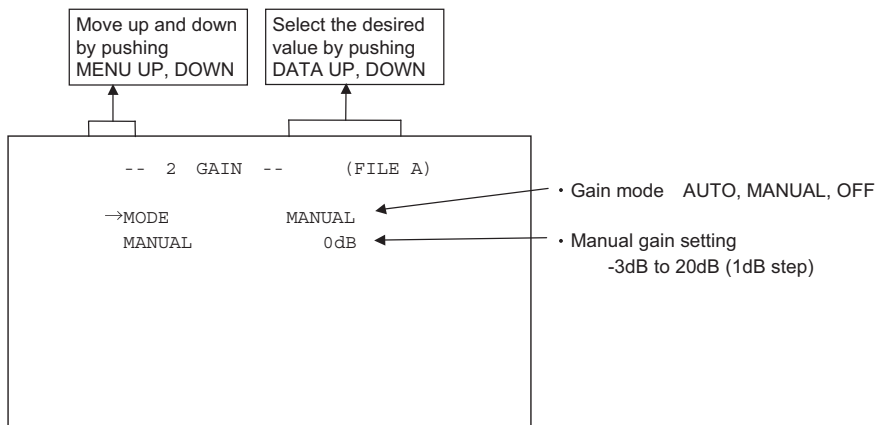

- ① Move the “→” to MANUAL by pushing the [MENU UP], [MENU DOWN] buttons.
- ② Select the desired value of manual gain by pushing the [DATA UP], [DATA DOWN] buttons.

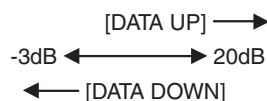

### ( 3 ) WHT BAL (White balance)

The WHT BAL has two modes; AWB, MANUAL.

Move the "→" to MODE, push the [DATA UP], [DATA DOWN], and select one of the two modes: AWB, MANUAL.

#### (3. 1) Changing the setting in AWB (Automatic White Balance) mode

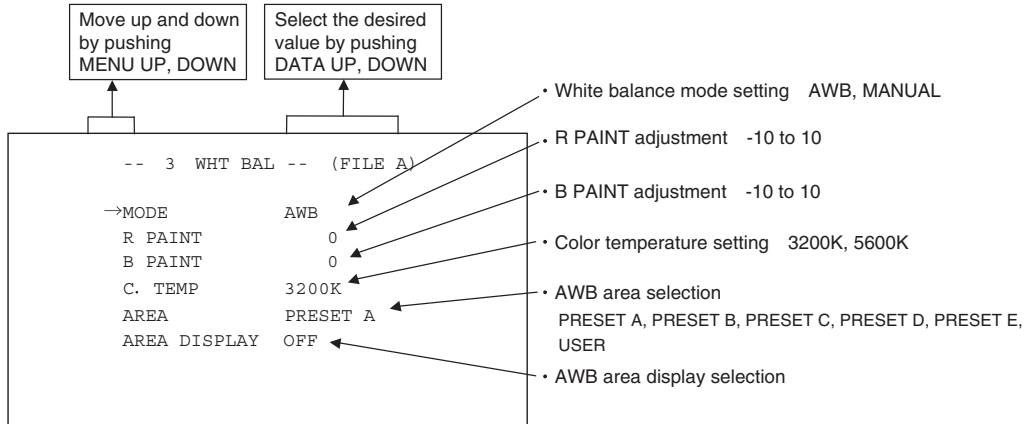

##### (a) Changing color temperature setting

- ① Move the "→" to C.TEMP by pushing the [MENU UP], [MENU DOWN] buttons.
- ② Select either 3200K or 5600K by pushing the [DATA UP], [DATA DOWN] buttons.

##### (b) Changing R PAINT

- ① Move the "→" to R PAINT by pushing the [MENU UP], [MENU DOWN] buttons.
- ② Select the desired value of red paint by pushing the [DATA UP], [DATA DOWN] buttons.

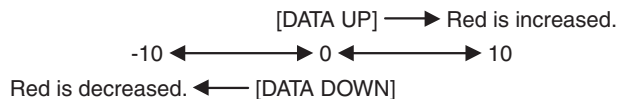

##### (c) Changing B PAINT

- ① Move the "→" to B PAINT by pushing the [MENU UP], [MENU DOWN] buttons.
- ② Select the desired value of blue paint by pushing the [DATA UP], [DATA DOWN] buttons.

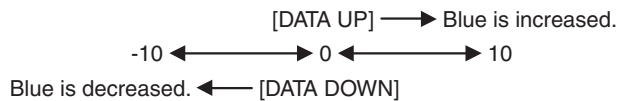

##### (d) Changing the contents of the zone area selected by AWB

- ① Move the "→" to AREA DISP by pushing the [MENU UP], [MENU DOWN] buttons.
- ② Select the desired area by pushing the [DATA UP], [DATA DOWN] buttons.

The available picture area is shown by the shading correction on the screen that is divided into 64 parts.

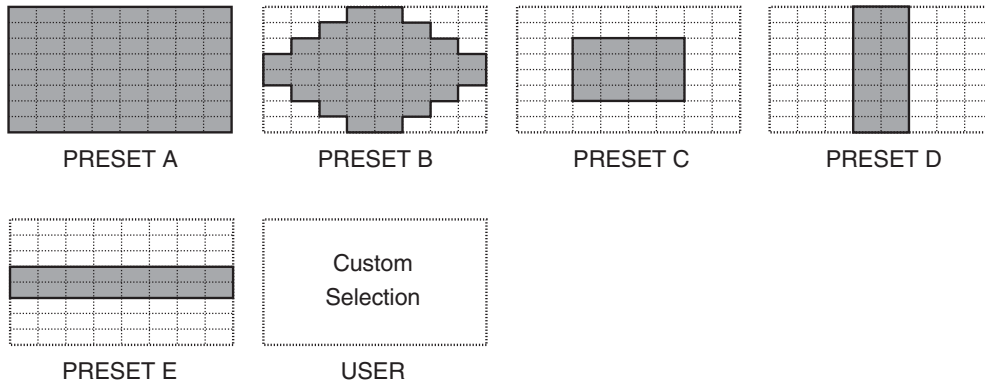

**(e) Confirming the contents of the zone area selected by AWB**

- ① Move the “→” to AREA DISP by pushing the [MENU UP], [MENU DOWN] buttons.
- ② Area screen appears by pushing the [DATA UP], [DATA DOWN] buttons.  
When AREA is set to USER, the setting can be changed on the area menu. When changing the area, refer to the item “7.2 (9) Setting USER area”.
- ③ Push the [DISP] button to return to the menu.

**(3.2) Changing gain in MANUAL mode**

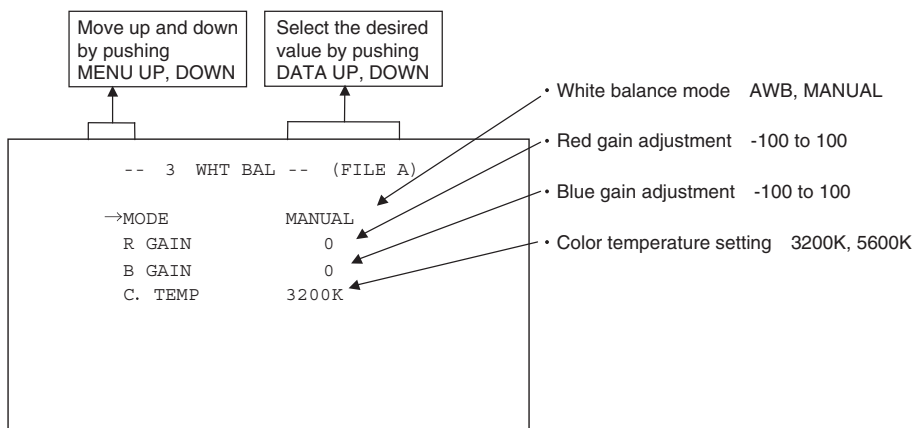

**(a) Changing the red gain**

- ① Move the “→” to R GAIN by pushing the [MENU UP], [MENU DOWN] buttons.
- ② Select the desired value of red gain by pushing the [DATA UP], [DATA DOWN] buttons.

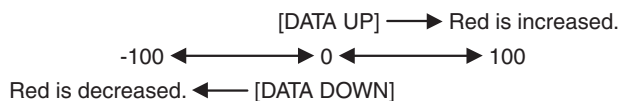

**(b) Changing the blue gain**

- ① Move the “→” to B GAIN by pushing the [MENU UP], [MENU DOWN] buttons.
- ② Select the desired value of blue gain by pushing the [DATA UP], [DATA DOWN] buttons.

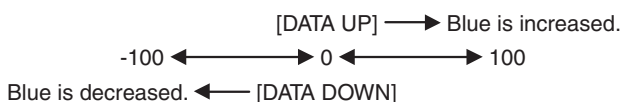

## (4) PROCESS1

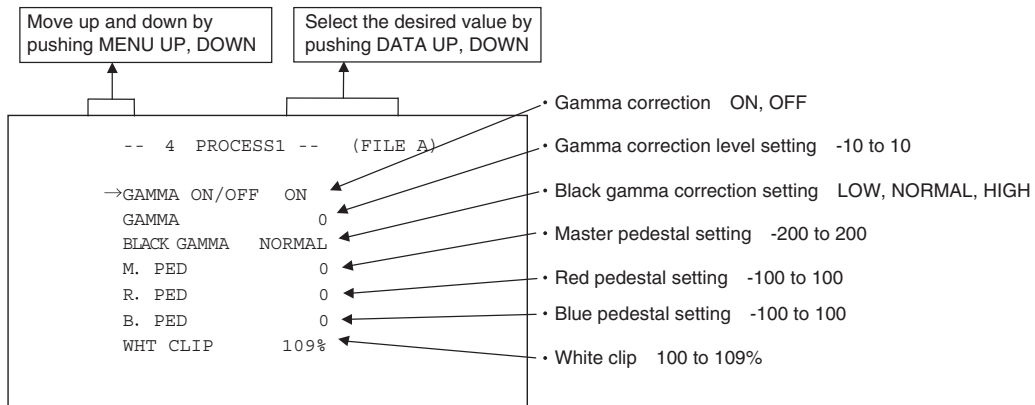

### (4.1) Changing gamma correction ON/OFF

- ① Move the “→” to GAMMA ON/OFF by pushing the [MENU UP], [MENU DOWN] buttons.
- ② Select either ON or OFF by pushing the [DATA UP], [DATA DOWN] buttons.  
When ON is selected, menu will show the GAMMA and BLACK GAMMA selections. When OFF is selected, GAMMA and BLACK GAMMA are not displayed. So the setting for GAMMA and BLACK GAMMA cannot be made.

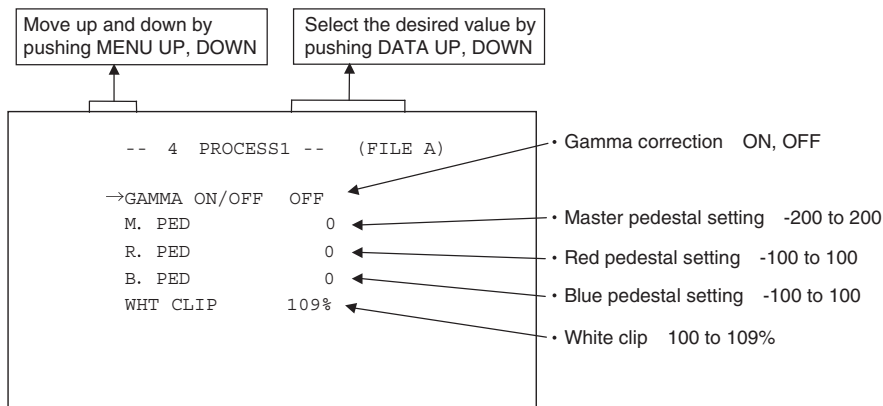

Menu when GAMMA OFF is selected.

### (4.2) Changing gamma correction level

- ① Move the “→” to GAMMA by pushing the [MENU UP], [MENU DOWN] buttons.
- ② Select the desired value of gamma correction level by pushing the [DATA UP], [DATA DOWN] buttons.

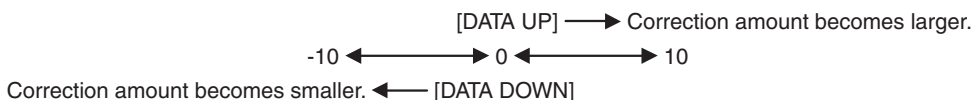

※ When OFF is selected in GAMMA ON/OFF selection line, the gamma correction level change cannot be changed.

### (4.3) Changing black gamma correction level

- ① Move the “→” to BLACK GAMMA by pushing the [MENU UP], [MENU DOWN] buttons.
- ② Select black gamma correction by pushing the [DATA UP], [DATA DOWN] buttons.

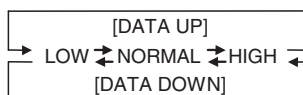

※ When OFF is selected in GAMMA ON/OFF selection line, the display BLACK GAMMA turns off automatically. So the black gamma correction level change cannot be changed.

#### (4.4) Changing pedestal

##### (a) Changing master pedestal

- ① Move the “→” to M. PED by pushing the [MENU UP], [MENU DOWN] buttons.
- ② Select the desired value of the master pedestal by pushing the [DATA UP], [DATA DOWN] buttons.



##### (b) Changing R. PED (red pedestal)

- ① Move the “→” to R. PED by pushing the [MENU UP], [MENU DOWN] buttons.
- ② Select the desired value of red pedestal by pushing the [DATA UP], [DATA DOWN] buttons.

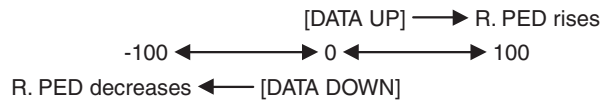

##### (c) Changing B. PED (blue pedestal)

- ① Move the “→” to B. PED by pushing the [MENU UP], [MENU DOWN] buttons.
- ② Select the desired value of blue pedestal by pushing the [DATA UP], [DATA DOWN] buttons.

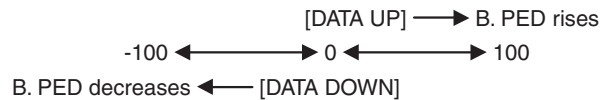

#### (4.5) Change of white clip

##### (a) Changing master pedestal

- ① Move the “→” to WHT CLIP by pushing the [MENU UP], [MENU DOWN] buttons.
- ② Select the white clip level by pushing the [DATA UP], [DATA DOWN] buttons.

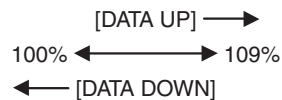



## (5) PROCESS2

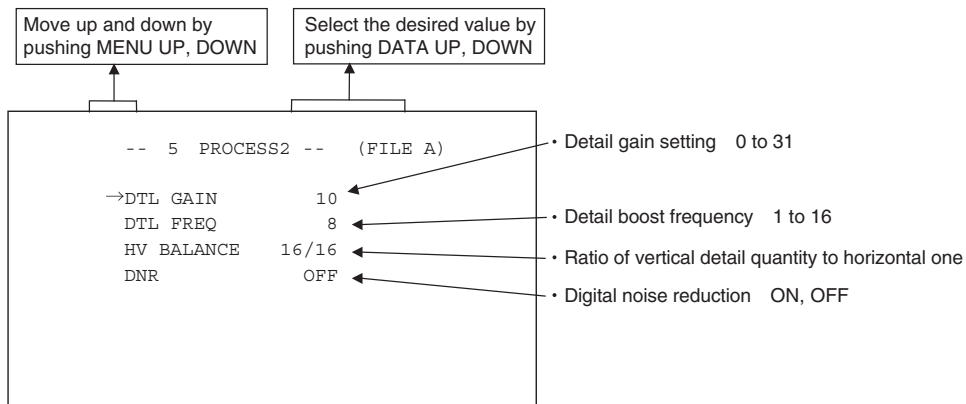

### (5.1) Changing detail (outline) gain

- ① Move the "→" to DTL GAIN by pushing the [MENU UP], [MENU DOWN] buttons.
- ② Select the desired value of the detail gain by pushing the [DATA UP], [DATA DOWN] buttons.

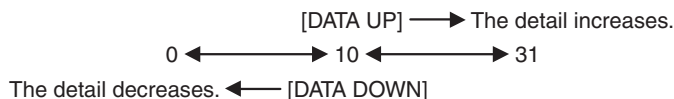

### (5.2) Change of detail boost frequency

This is the item for setting the screen outline thickness.

- ① Move the "→" to DTL FREQ by pushing the [MENU UP], [MENU DOWN] buttons.
- ② Select the detail boost frequency by pushing the [DATA UP], [DATA DOWN] buttons.

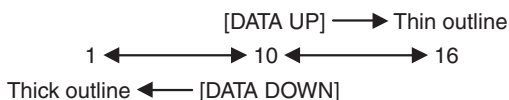

### (5.3) Change of horizontal and vertical detail balance

This is the item for changing the ratio of the vertical detail quantity to the horizontal one.

- ① Move the "→" to HV BALANCE by pushing the [MENU UP], [MENU DOWN] buttons.
- ② Select the vertical detail quantity by pushing the [DATA UP], [DATA DOWN] buttons.

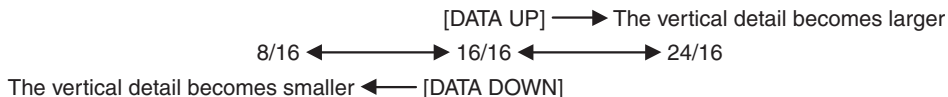

### (5.4) Changing DNR (Digital Noise Reduction)

- ① Move the "→" to DNR by pushing the [MENU UP], [MENU DOWN] buttons.
- ② Select either ON or OFF by pushing the [DATA UP], [DATA DOWN] buttons.

#### Note:

When DNR is set to ON, noise is reduced, but shooting a fast moving object may affect the video clarity.

## (6) PROCESS3

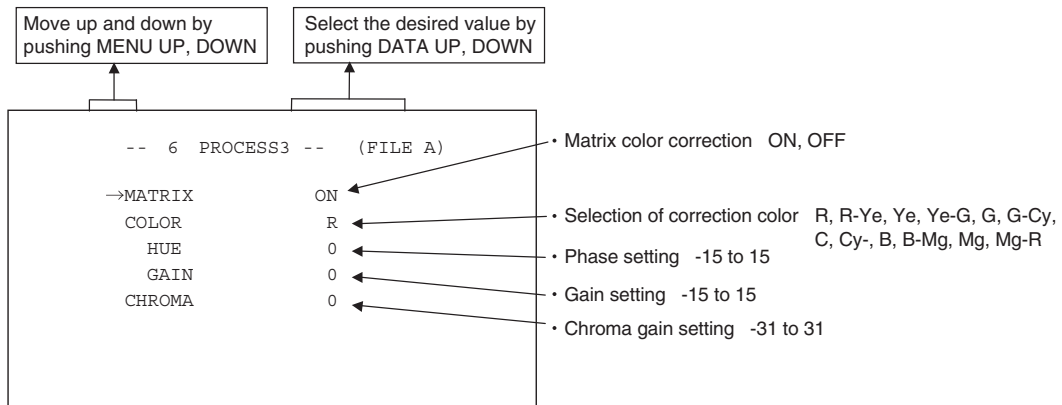

### (6.1) Changing matrix color correction ON/OFF

- ① Move the "→" to MATRIX by pushing the [MENU UP], [MENU DOWN] buttons.
- ② Select either ON or OFF by pushing the [DATA UP], [DATA DOWN] buttons.

### (6.2) Selection of matrix correction color

- ① Move the "→" to COLOR by pushing the [MENU UP], [MENU DOWN] buttons.
- ② Select the correction color by pushing the [DATA UP], [DATA DOWN] buttons.

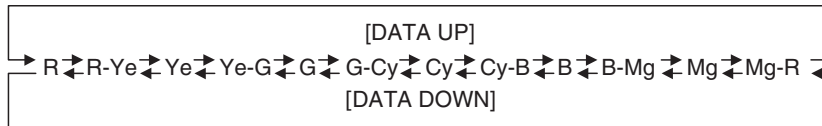

\* If the matrix color correction is OFF, correction color cannot be selected.

### (6.3) Changing MATRIX setting

- ① Move the "→" to the desired item by pushing the [MENU UP], [MENU DOWN] buttons.
- ② Select the desired value of color by pushing the [DATA UP], [DATA DOWN] buttons.

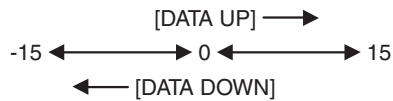

\* If the matrix color correction is OFF, correction color cannot be selected.

### (6.4) Change of chroma gain

- ① Move the "→" to CHROMA by pushing the [MENU UP], [MENU DOWN] buttons.
- ② Change the chroma gain by pushing the [DATA UP], [DATA DOWN] buttons.

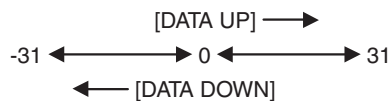

## (7) SYNC

When an external sync signal is input, the display changes from INT (internal sync) to EXT. (external sync) automatically.

INT ←→ EXT

### (7.1) INT screen

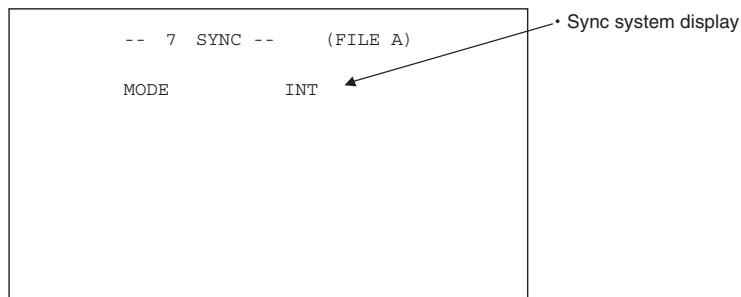

### (7.2) Changing EXT. setting

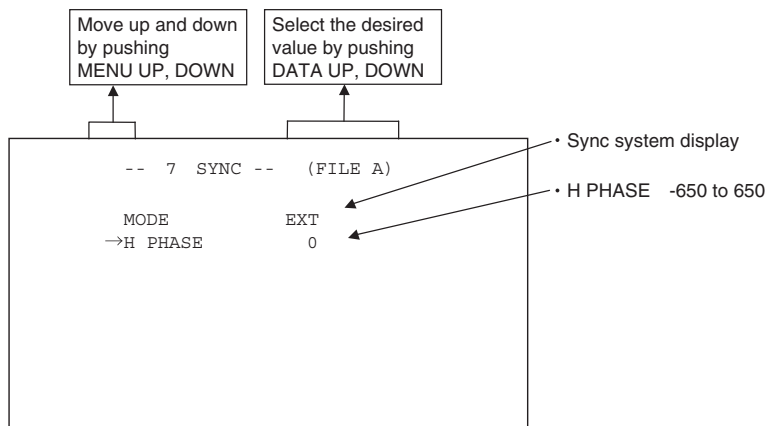

#### (a) Adjusting horizontal phase

- ① When it comes to EXT mode, the "→" move to H PHASE.
- ② Select the desired value of horizontal phase by pushing the [DATA UP], [DATA DOWN] buttons.

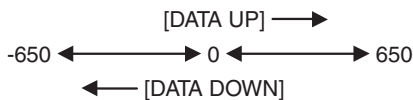

\* If the phase difference is big, keep pressing [DATA UP]/[DATA DOWN] button for a while. This will make the setting change by increments of ten.

## (8) OPTION

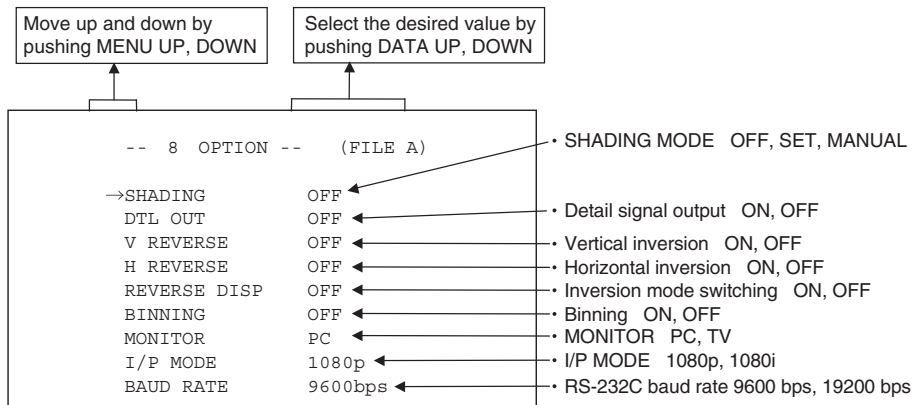

### (8.1) Changing shading correction mode

- ① Move the "→" to SHADING by pushing the [MENU UP], [MENU DOWN] buttons.
- ② Select SET, MANUAL or OFF by pushing the [DATA UP], [DATA DOWN] buttons.

\* When connecting IK-HR3H (CMOS camera head which is scheduled to be available in September, 2013), this mode will not be displayed.

### (8.2) Changing manual shading correction mode

- ① Move the "→" to MANUAL by pushing the [MENU UP], [MENU DOWN] buttons.
- ② Select the desired value of manual shading correction by pushing the [DATA UP], [DATA DOWN] buttons.

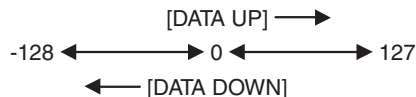

\* When the shading correction mode is set to anything other than MANUAL, the display turns off, and the setting cannot be adjusted.

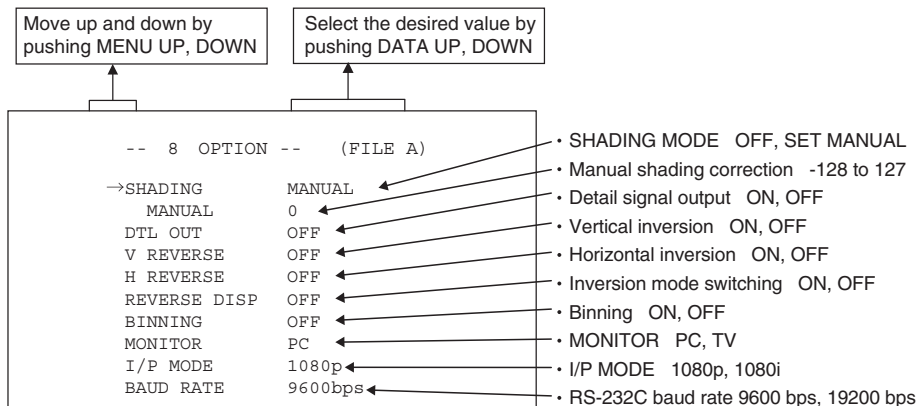

Menu when SHADING MANUAL is selected

\* When connecting IK-HR3H (CMOS camera head which is scheduled to be available in September, 2013), this mode will not be displayed.

### (8.3) Changing detail signal output

- ① Move the "→" to DTL OUT by pushing the [MENU UP], [MENU DOWN] buttons.
- ② Select either ON (detail signal only is output) or OFF (video signal) by pushing the [DATA UP], [DATA DOWN] buttons.

#### (8. 4) Change of vertical inversion setting

- ① Move the “→” to V REVERSE by pushing the [MENU UP], [MENU DOWN] buttons.
- ② Select ON (Vertical inversion image appears.) or OFF by pushing the [DATA UP], [DATA DOWN] buttons.

#### (8. 5) Change of horizontal inversion setting

- ① Move the “→” to H REVERSE by pushing the [MENU UP], [MENU DOWN] buttons.
- ② Select ON (Horizontal inversion image appears.) or OFF by pushing the [DATA UP], [DATA DOWN] buttons.

#### (8. 6) Switching of inversion mode display

- ① Move the “→” to REVERSE DISP by pushing the [MENU UP], [MENU DOWN] buttons.
- ② Select ON or OFF by pushing the [DATA UP]-[DATA DOWN] buttons.  
When ON is set, the setting status of vertical/horizontal inversion is displayed in the lower right part of the screen.

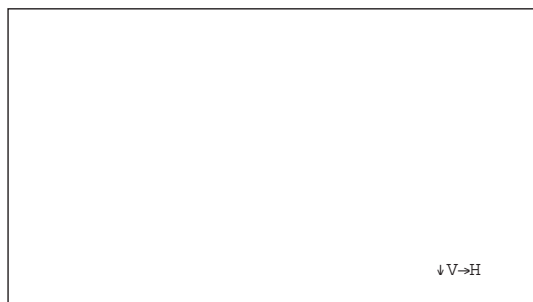

- ※ ↓V...Vertical inversion is effective.
- ※ →H...Horizontal inversion is effective.

#### (8. 7) Change of binning setting

This is a function for increasing the sensitivity by adding pixels for horizontal and vertical directions.

- ① Move the “→” to BINNING by pushing the [MENU UP], [MENU DOWN] buttons.
- ② Select ON or OFF by pushing the [DATA UP]-[DATA DOWN] buttons.

##### Note:

Turning of binning setting ON (effective) lowers the resolution.

#### (8. 8) Change of monitor receiver types

- ① Move the “→” to MONITOR by pushing the [MENU UP], [MENU DOWN] buttons.
- ② Select PC or TV by pushing the [DATA UP]-[DATA DOWN] buttons.
  - PC: for use of PC monitor
  - TV: for use of monitor TV

#### (8. 9) Change of I/P mode

Switching between Interlace and Progressive is performed.

- ① Move the “→” to I/P MODE by pushing the [MENU UP], [MENU DOWN] buttons.
- ② Select 1080p or 1080i by pushing the [DATA UP]-[DATA DOWN] buttons.
  - 1080p: for use of 1080p (progressive)
  - 1080i: for use of 1080i (interlace)

##### Note:

No image is displayed on the monitor that is not in the correct setting mode. In that case, refer to the item 6.6 “Switching of I/P Modes” to return the mode to the original one.

#### (8. 10) Changing RS-232C baud rate

- ① Move the “→” to BAUD RATE by pushing the [MENU UP], [MENU DOWN] buttons.
- ② Select either 9600bps or 19200bps by pushing the [DATA UP], [DATA DOWN] buttons.

## (9) Setting USER area

- When USER is selected for the AREA of the automatic shutter or for AWB, the light measurement zones can be changed.
- The USER area is composed of 64 zones with 8 (vertical) x 8 (horizontal) areas, and each area can be set to ON/OFF.

### ① Set the output to area menu.

Set the output to the area menu by referring to the item “7.2 (1.1) (e) Confirming the contents of the measurement light area selected by automatic shutter” and “7.2 (3.1) (e) Confirming the contents of the measurement light area selected by AWB”.

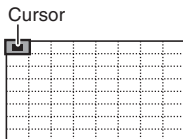

### ② Move the cursor to the zone to be appeared.

The cursor moves up, down, right and left by pushing the [MENU UP], [MENU DOWN], [DATA UP], [DATA DOWN] buttons.

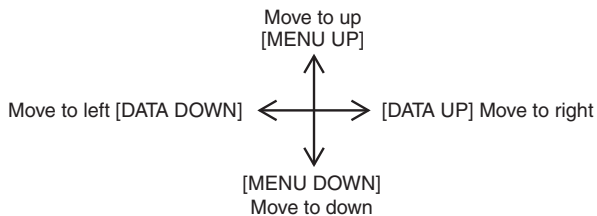

### ③ Select ON/OFF for the zone.

Select ON (effective) or OFF (ineffective) by pushing the [PAGE] button.

When ON is selected, the selected area will be displayed brightly, and when OFF is selected, it will be dimmed.

### ④ Push [DISP] button to return to the menu.

#### Note:

OFF can not be selected for all 64 zones because the automatic shutter function and AWB function do not perform correctly. (“AREA NG NOT AVAILABLE” displays.)

## ( 10 ) Returning to factory settings

The contents set of each scene file can be returned to the factory default status (preset status).

- (1) Select a scene file to set to the factory default status by pressing the [FILE] button.
- (2) If the color bar pattern or characters are displayed on the screen, press the [DISP] button to disable the color bar pattern and character display.
- (3) Push [MENU DOWN] and [DATA DOWN] buttons simultaneously for approx. 1 second.
- (4) The preset operation starts. When the preset operation finishes, the character PRESET OK is displayed for approx. 1 second.

\* Only the scene files selected presently are set at the time of shipment from the factory. If you wish to have all the scene files set as the factory shipment setting, perform the above operation for each scene file.

## 7.3 External Sync

When using the unit with an external sync signal, input the external sync signal to EXT. SYNC terminal on the rear panel.

When the external sync signal is input, the camera automatically switches its sync from the internal sync to the external sync.

### ( 1 ) External sync signal input conditions

SYNC (75Ω unbalanced) ±0.3 V ±6 dB

### ( 2 ) External sync frequency range

1080p/59.94Hz Setting : H : 67.433 kHz ± 35 ppm  
   : V : 59.94 Hz ± 35 ppm  
 1080p/50Hz Setting    : H : 56.250 kHz ± 35 ppm  
   : V : 50 Hz ± 35 ppm  
 1080i/59.94Hz Setting : H : 33.716 kHz ± 35 ppm  
   : V : 59.94 Hz ± 35 ppm  
 1080i/50Hz Setting    : H : 28.125 kHz ± 35 ppm  
   : V : 50 Hz ± 35 ppm

### ( 3 ) Using the unit with external sync signal

Adjust H (Horizontal) phase if necessary to match the output of multiple cameras.

When adjusting H (Horizontal) phase, refer to the item “7.2 (7) SYNC”.

#### (3. 1) H (Horizontal) phase adjustment

Observe the external sync signal and the video signal output waveform of the unit with a dual trace oscilloscope, and adjust H phase so that the H phases match.

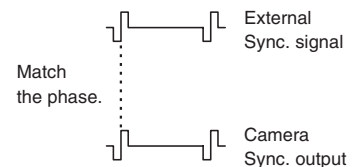

## 7.4 Synchro. Scan Operation

The shutter speed can be set by the horizontal scanning period (1H).

### ( 1 ) Setting by 1H

1/1125H to 1122/1125H stands for the setting by the 1H and the shutter speed can be set by the 1H.

## 8. BEFORE MAKING SERVICE CALL

Symptom	Items to be checked
No image	<ul style="list-style-type: none"><li>• Is power supplied correctly?</li><li>• Is the power switch on, and the power LED illuminated?</li><li>• Is the lens iris adjusted correctly?</li><li>• Are the camera and video cables connected correctly?</li><li>• Is the shutter mode set correctly?</li><li>• Is the monitor on, and in working condition?</li></ul>
Poor color	<ul style="list-style-type: none"><li>• Is the monitor adjusted correctly?</li><li>• Is the white balance of the camera adjusted correctly?</li><li>• Are the matrix color correction and chroma gain set correctly?</li><li>• Is the illumination sufficient?</li></ul>
Noise appears	<ul style="list-style-type: none"><li>• Is the camera cable connected securely?</li></ul>



## 9. SPECIFICATIONS

\* These conditions are only satisfied when the camera control unit is connected to camera head model # IK-HD3H.

Power supply	DC 12 V $\pm$ 10 %
Power consumption	Approx. 11.4W (including the camera head) (with the power supply voltage of 12V)
Pickup system	RGB, 3CMOS, Micro prism system
Image sensor	1/3 inch CMOS
Effective pixels	Horizontal: 1944 pixels, vertical: 1092 pixels
Output pixels	Horizontal: 1920 pixels, vertical: 1080 pixels
Scanning system	Progressive/Interlace
Scan frequency	Horizontal: 67.433kHz, vertical: 59.94Hz (at setting of 1080p/59.94Hz) Horizontal: 56.250kHz, vertical: 50Hz (at setting of 1080p/50Hz) Horizontal: 33.716kHz, vertical: 59.94Hz (at setting of 1080i/59.94Hz) Horizontal: 28.125kHz, vertical: 50Hz (at setting of 1080i/50Hz)
Sync system	Internal/External (Automatic switching)
Horizontal resolution	1000TV lines standard
Vertical resolution	1000TV lines standard
Sensitivity	F10 standard (2000 lx, 3000K at 59.94Hz setting), F11 standard (2000 lx, 3000K at 50Hz setting)
Minimum illumination	4.8 lx (at 59.94Hz setting, F2.2, sensitivity +20dB, BINNING: ON) 4.0 lx (at 50Hz setting, F2.2, sensitivity +20dB, BINNING: ON) 9.6 lx (at 59.94Hz setting, F2.2, sensitivity +20dB, BINNING: OFF) 8.0 lx (at 50Hz setting, F2.2, sensitivity +20dB, BINNING: OFF)
SN ratio	56 dB standard (GAIN 0dB, DNR OFF, DTL GAIN 0, GAMMA OFF, MATRIX OFF and C.TEMP 5600K during light elimination)
Ambient temperature	0°C to 40°C (32°F to 104°F)
Ambient humidity	Less than 90% (non condensing)
Weight	Approx. 610 g (1.35 lbs)
External dimension	110(W) $\times$ 40(H) $\times$ 186(D) mm (4.33"(W) $\times$ 1.57"(H) $\times$ 7.32"(D)) (excluding protrusions)
Scene file (user memories)	A, B, C, D, E
White balance	AWB (Automatic white balance), MANUAL
Gain	AUTO (Automatic gain control), MANUAL, OFF (0dB)
Output signal	DVI (digital RGB) DVI-D terminal 1080/59.94p, 1080/50p, 1080/59.94i, 1080/50i
External sync input	SYNC 3 values $\pm$ 0.3V $\pm$ 6dB 75 $\Omega$ unbalanced BNC connector Horizontal: 67.433kHz $\pm$ 35ppm, vertical 59.94Hz $\pm$ 35ppm (at 1080p/59.94Hz setting) Horizontal: 56.250kHz $\pm$ 35ppm, vertical 50Hz $\pm$ 35ppm (at 1080p/50Hz setting) Horizontal: 33.716kHz $\pm$ 35ppm, vertical 59.94Hz $\pm$ 35ppm (at 1080i/59.94Hz setting) Horizontal: 28.125kHz $\pm$ 35ppm, vertical 50Hz $\pm$ 35ppm (at 1080i/50Hz setting)
Sync signal output	SYNC 3 values $\pm$ 0.3V $\pm$ 0.1V 75 $\Omega$ unbalanced BNC connector Horizontal:33.716kHz $\pm$ 35ppm, vertical:59.94Hz $\pm$ 35ppm (at 59.94Hz setting) Horizontal:28.125kHz $\pm$ 35ppm, vertical:50Hz $\pm$ 35ppm (at 50Hz setting)
Interface	Serial data interface (compliant with RS-232C)
Optional parts	IK-HD3H (1/3 inch 3CMOS camera head) IK-HR3H (1/3 inch CMOS color camera head) (Scheduled to be available in September, 2013) EXC-3HD03 (Approx. 3 m (118") Camera cable) EXC-3HD06 (Approx. 6 m (236") Camera cable) EXC-3HD10 (Approx. 10 m (394") Camera cable) EXC-3HD15 (Approx. 15 m (1181") Camera cable)

● Design and specifications are subject to change without notice.

# 10. EXTERNAL APPEARANCE DIAGRAM

Unit : mm [inch]

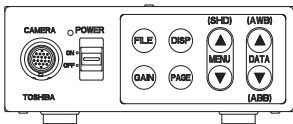
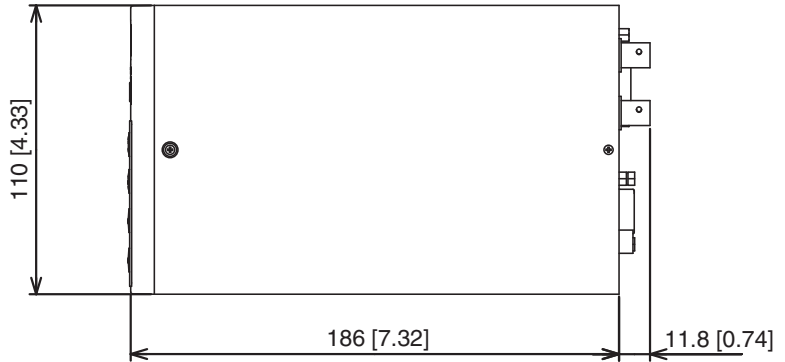

[Front]

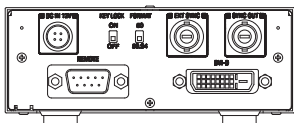
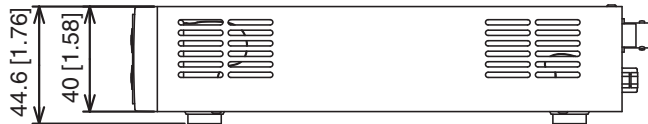

[Rear]

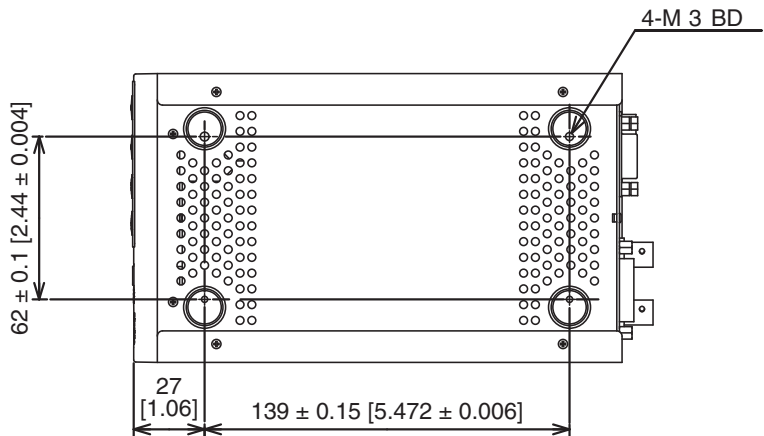



## Limited Warranty – TOSHIBA Camera Control Unit

The Imaging Systems Division of Toshiba America Information Systems, Inc. ("ISD") makes the following limited warranty with regard to this CMOS Camera ("Product"). These limited warranties apply to the Original End-User "You(r)".

### One (1) Year Limited Warranty of Labor and Parts

ISD warrants that this Product will perform in accordance with specifications for a period of one (1) year from the date of purchase by the Original End-User. During this one (1) year period, ISD will repair or replace the Product, if it does not perform as warranted. In order to take advantage of this Limited Warranty, You must: (a) deliver the Product to an ISD Authorized Service Provider ("ASP"); and (b) pay all transportation and insurance charges for shipment of the Product to the ASP. ISD reserves the right to substitute factory refurbished parts in place of those in need of repair.

### Instruction Manual (Owner's Manual):

You should read the Instruction Manual (Owner's Manual) thoroughly before operating this Product. Before seeking warranty service, you should check the troubleshooting guide in the Instruction Manual (Owner's Manual) and follow the instructions to correct the problem.

### Your Responsibilities

This Limited Warranty is subject to the following conditions:

1. You must provide the bill of sale or proof of purchase at the time that warranty service is required.
2. All warranty servicing of the Product must be made by an ISD Authorized Service Provider.
3. You must pack the Product in its original carton using the original packing material, then insert the original carton containing the Product into another carton with additional packing material before shipping the Product to an ASP.
4. Prepay all transportation and insurance costs.

### DISCLAIMERS:

**ALL OTHER EXPRESS OR IMPLIED WARRANTIES ON THIS PRODUCT, INCLUDING THE IMPLIED WARRANTIES OF MERCHANTABILITY AND FITNESS FOR A PARTICULAR PURPOSE, ARE HEREBY DISCLAIMED. SOME STATES DO NOT ALLOW THE EXCLUSION OF IMPLIED WARRANTIES OR LIMITATIONS ON HOW LONG AN IMPLIED WARRANTY LASTS, SO THE ABOVE LIMITATIONS MAY NOT APPLY TO YOU.**

**IF THIS PRODUCT IS NOT IN GOOD WORKING ORDER AS WARRANTED ABOVE, YOUR SOLE AND EXCLUSIVE REMEDY SHALL BE THE REPAIR OR REPLACEMENT OF THE PRODUCT. IN NO EVENT WILL ISD OR ITS PARENT COMPANY OR ANY ASP BE LIABLE TO YOU OR ANY THIRD PARTY FOR ANY DAMAGES IN EXCESS OF THE PURCHASE PRICE OF THE PRODUCT. THIS LIMITATION APPLIES TO DAMAGES OF ANY KIND, INCLUDING ANY DIRECT OR INDIRECT DAMAGES, LOST PROFITS, LOST SAVINGS OR OTHER SPECIAL, INCIDENTAL, EXEMPLARY OR CONSEQUENTIAL DAMAGES, WHETHER FOR BREACH OF CONTRACT, TORT OR OTHERWISE, OR WHETHER ARISING OUT OF THE USE OF OR INABILITY TO USE SUCH PRODUCT, EVEN IF ISD, ITS PARENT COMPANY, OR AN ASP HAS BEEN ADVISED OF THE POSSIBILITY OF SUCH DAMAGES OR OF ANY CLAIM BY ANY OTHER PARTY. SOME STATES DO NOT ALLOW THE EXCLUSION OR LIMITATION OF INCIDENTAL OR CONSEQUENTIAL DAMAGES FOR SOME PRODUCTS, SO THE ABOVE LIMITATIONS OR EXCLUSIONS MAY NOT APPLY TO YOU.**

**THIS LIMITED WARRANTY GIVES YOU SPECIFIC LEGAL RIGHTS, AND YOU MAY ALSO HAVE OTHER RIGHTS WHICH MAY VARY FROM STATE TO STATE.**

**THIS LIMITED WARRANTY SHALL BE VOID IF THE PRODUCT OR PARTS HAVE BEEN SUBJECT TO MISUSE, ABUSE, ACCIDENT, IMPROPER INSTALLATION, IMPROPER MAINTENANCE, OR USE IN VIOLATION OF ISD'S WRITTEN INSTRUCTIONS, OR WHERE THE PRODUCT HAS BEEN ALTERED OR MODIFIED WITHOUT ISD'S PRIOR AUTHORIZATION, OR UPON THE REMOVAL OR ALTERATION OF ISD'S FACTORY SERIAL NUMBER. LABOR SERVICE CHARGES FOR PRODUCT INSTALLATION, SET UP AND ADJUSTMENT OF CONTROLS ARE NOT COVERED BY THIS LIMITED WARRANTY.**

Questions? If you have any questions, please check ISD's Web Site for support and a current e-mail contact to where you can send e-mails:

**Web Site:** <http://www.toshibacameras.com/>

*No person, agent, distributor, dealer, authorized service provider, or company is authorized to change, modify, or extend the terms of this Limited Warranty in any manner whatsoever. The time within which an action must be commenced to enforce any obligation of ISD arising under this Limited Warranty or under any statute, or law of the United States or any state thereof, is hereby limited to one (1) year from the end of the Limited Warranty period. This limitation does not apply to implied warranties arising under state law. Some states do not permit limitation of the time within which You may bring an action beyond the limits provided by state law, so the above provision may not apply to You. This Limited Warranty gives You specific legal rights and You may also have other rights which vary from state to state.*

### TOSHIBA AMERICA INFORMATION SYSTEMS, INC.

Imaging Systems Division  
9740 Irvine Boulevard, Irvine, CA 92618-1697

Copyright© 2013 Toshiba corporation, Toshiba America Information systems, Inc. All rights reserved.

**TOSHIBA**